

NOTE:
OVERALL SHIPPING DIMENSION: 4'-11" L X 2'-5" W X 4'-2" H

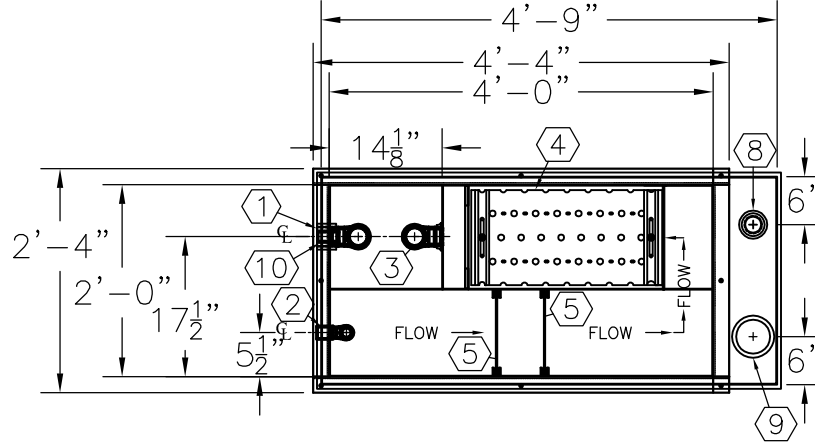

ITEM	SIZE	SUGGESTED FUNCTION
1	2"	EFFLUENT
2	1"	INFLUENT
3	2"	TRANSFER PIPE
4		COALESCER
5		DEBRIS PLATES
6	2" X 9"	OIL EQUALIZING ORIFICE
7		COVER, DWG."CVB001"
8	2"	SECONDARY WORKING VENT
9	4"	SECONDARY CONTAINMENT EMERGENCY VENT
10	1"	FLOAT SENSOR NPT FTG.
11	2"	OIL DRAW W/PIPE

TANK SPECIFICATIONS

MATERIAL: PRIMARY TANK - 10 GA.

TOP VIEW
 TOP COVER REMOVED FOR CLARITY
 REFER TO DWG. "CVB001" FOR COVER DETAIL

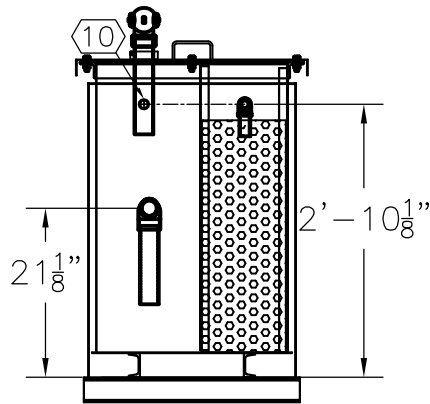

LEFT END VIEW

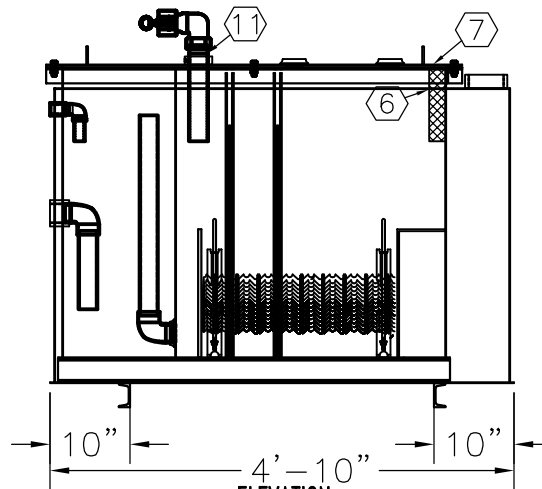

ELEVATION
 FRONT FACE & BHD REMOVED FOR CLARITY

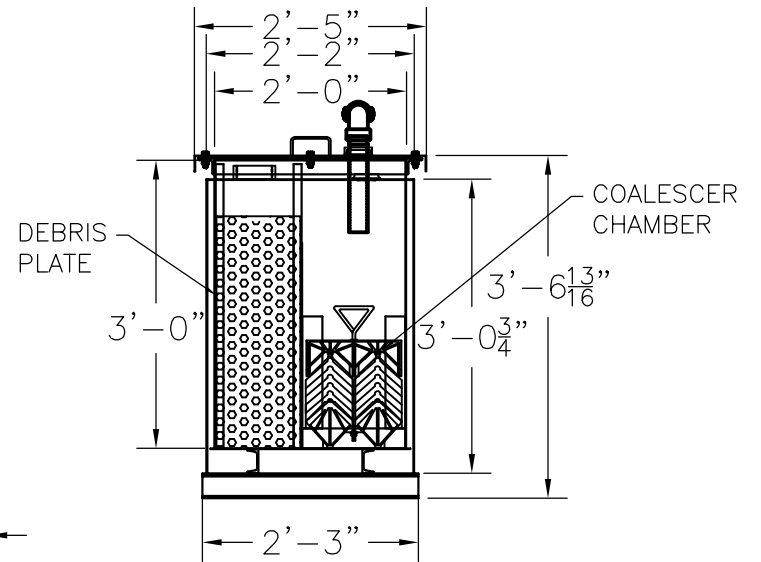

RIGHT END VIEW

PRODUCT CODE	GALLONS	DESCRIPTION	OVERALL SIZE	SHIP WT.
WSAA1100DS000	100	DOUBLE WALL OIL WATER SEPARATOR (10 GPM)	4'-10" L X 2'-3" W X 3'-7" H	1,100 LBS.

CONTAINMENT SOLUTIONS®

THIS DRAWING AND DESIGN SHOWN HEREIN IS THE PROPERTY OF CONTAINMENT SOLUTIONS. USE OR COPIES THEREOF CANNOT BE MADE WITHOUT WRITTEN CONSENT.

CUSTOMER NAME: _____
APPROVED BY: _____ DATE: _____

DRAWN BY: _____ DATE DRAWN: 01-01-14
 DWG NUMBER: 5100267 SCALE: 1:32
 REV: _____ REV BY: _____ DATE: _____ SHEET: 1 OF 1