

NOTE:
 OVERALL SHIPPING DIMENSION: 13'-8" L X 8'-6" W X 9'-4" H

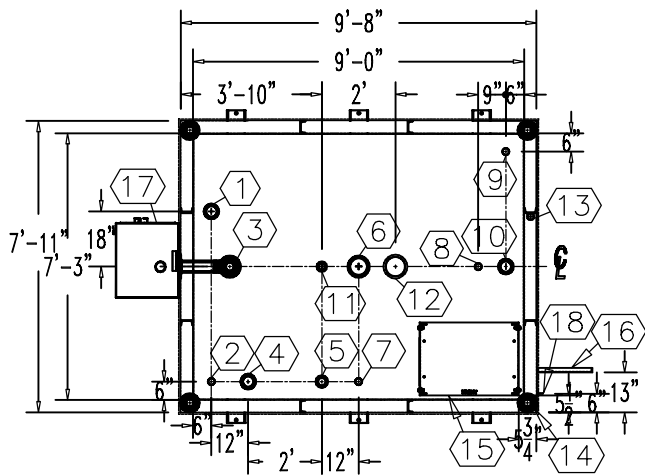

ITEM	SIZE	SUGGESTED FUNCTION
1	4"	PHASE 1 VAPOR RECOVERY/SPARE
2	2"	CLOCK LEVEL GAUGE
3	6"	FILL W/3" FILL LIMITER
4	4"	ELECTRONIC LEVEL GAUGE (OPTIONAL)
5	3"	PRIMARY WORKING VENT W/RISER PIPE
6	6"	PRIMARY TANK EMERGENCY VENT
7	2"	SPARE
8	2"	SUCTION PUMP
9	2"	HIGH LEVEL ALARM
10	4"	SPARE
11	2"	SECONDARY WORKING VENT
12	8"	SECONDARY CONTAINMENT EMERGENCY VENT
13	2"	SECONDARY MONITOR PIPE
14	4"	FIRE RATED MATERIAL FILL
15	N/A	9822 DISPENSER BRACKET, DWG."PBB015"
16	N/A	DISPENSER BRACKET, DWG."DSB001"
17	3" PIPE	MORRISON 3QBB REMOTE FILL BOX, DWG."SBB202"
18	2" X 2"	GROUND CLIP, DWG."MCB004"

TANK SPECIFICATIONS

VENTING CAPACITY: PRIMARY TANK - 265,000 CUBIC FEET PER HOUR
 SECONDARY TANK - 288,000 CUBIC FEET PER HOUR
 MATERIAL: PRIMARY TANK - 1/4" THICK
 SECONDARY TANK - 3/16" THICK

THREADED CONNECTION (TYP.) SEE TOP VIEW
 2" STD. PIPE FOR MONITOR ACCESS

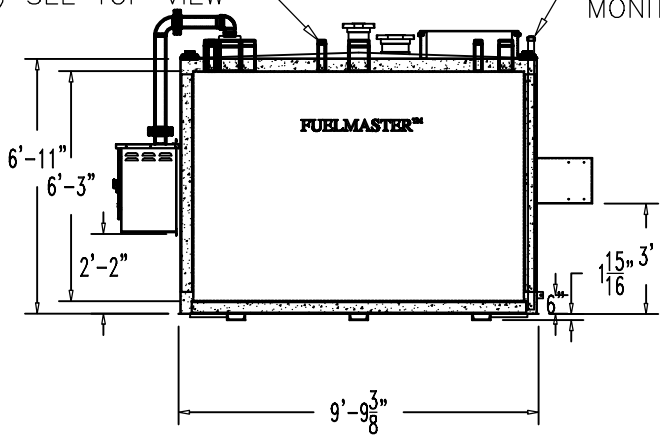

ELEVATION

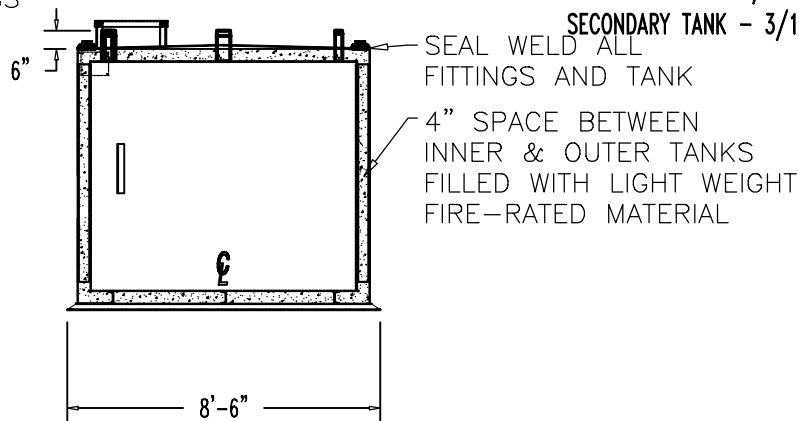

END VIEW

SEAL WELD ALL FITTINGS AND TANK
 4" SPACE BETWEEN INNER & OUTER TANKS FILLED WITH LIGHT WEIGHT FIRE-RATED MATERIAL

PRODUCT CODE	GALLONS	DESCRIPTION	OVERALL SIZE	SHIP WT.
FMAA103MVS001	3,000	U/L-2085 ABOVE GROUND VAULT TANK W/FUEL SYSTEM	9'-8" L X 7'-11" W X 7'-1" H	16,600 LBS.

THIS DRAWING AND DESIGN SHOWN HEREIN IS THE PROPERTY OF CONTAINMENT SOLUTIONS. USE OR COPIES THEREOF CANNOT BE MADE WITHOUT WRITTEN CONSENT.

CUSTOMER NAME: _____
APPROVED BY: _____ DATE: _____



DRAWN BY: D. ROVANG	DATE DRAWN: 01-01-14
DWG NUMBER: 5103546	SCALE: 1:64
REV: _____	REV BY: _____
DATE: _____	SHEET: 1 OF 1